

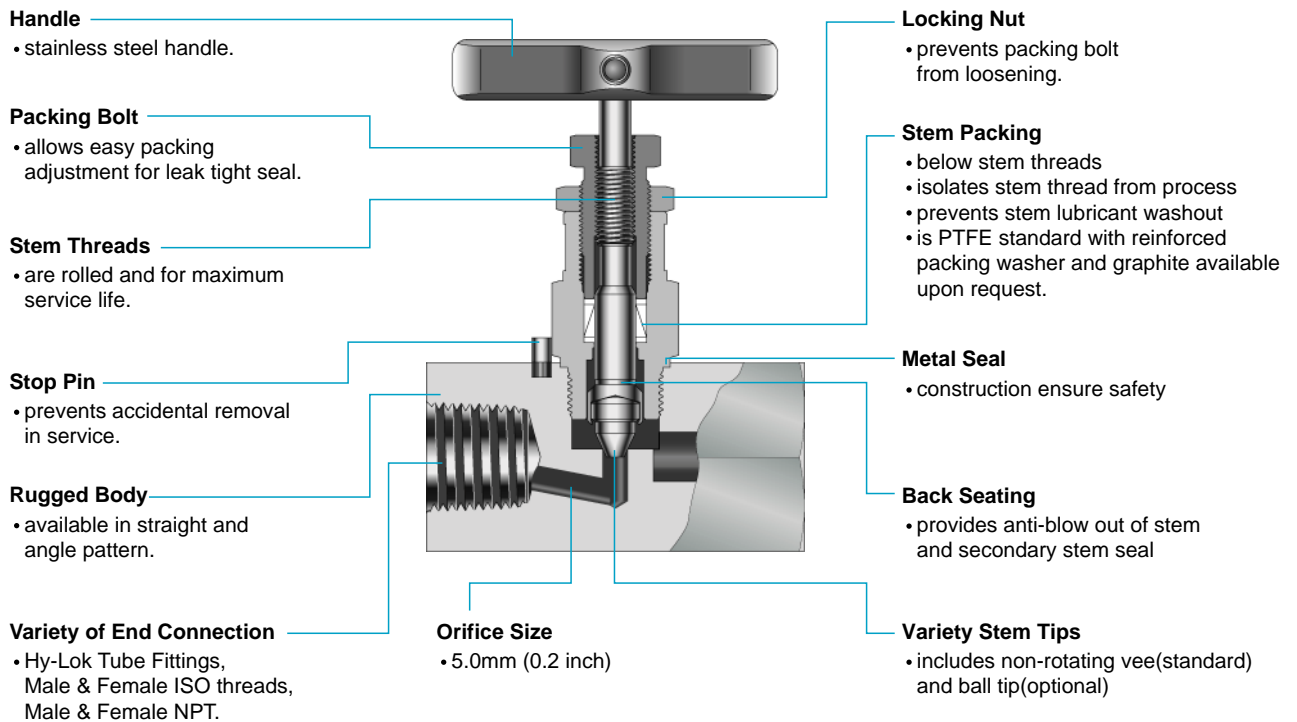

High Pressure Bar Stock Needle Valves

SVH Series



Ball Tip

Features

- **Pressure rating** up to 10,000psig(689 bar) @100°F(38°C)
- **Temperature range** from -65°F to 450°F(-23°C to 232°C) with standard PTFE packing and up to 1000°F (537°C) with optional graphite packing.
- **Body materials** available in 316 stainless steel, carbon steel and alloy 400
- 100% factory tested



SVH1 for 10,000psig

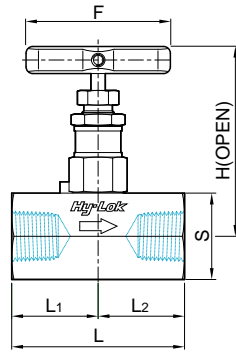

Straight pattern

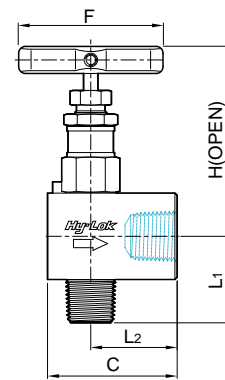

Angle pattern

Table of Dimensions

Basic Part No.	Orifice Hole	Cv	End Connections		Dimensions								
			Inlet	Outlet	L	L1	L2	C	S	F	H		
SVH1	F - 4N	5.0 (0.197)	0.52	1/4" Female NPT		52.4 (2.06)	26.2 (1.03)	26.2 (1.03)	57.2 (2.25)	38.1 (1.50)	64.0 (2.52)	90.0 (3.54)	
	F - 8N			1/2" Female NPT		66.7 (2.63)	33.3 (1.31)	33.3 (1.31)	62.5 (2.46)	41.0 (1.61)		91.5 (3.60)	
	F - 12N			3/4" Female NPT								77.8 (3.06)	44.5 (1.75)
	MF - 4N			1/4" Male NPT	1/4" Female NPT	40.5 (1.59)	26.2 (1.03)						
	MF - 6N			3/8" Male NPT	3/8" Female NPT								
	MF - 8N			1/2" Male NPT	1/2" Female NPT								

Dimensions in millimeters(inches) are for reference only, subject to change.

SVH2 for 6,000psig

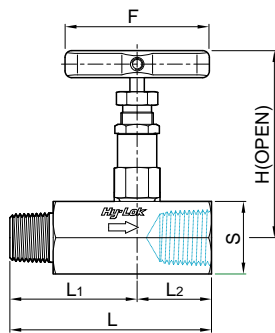

Straight pattern

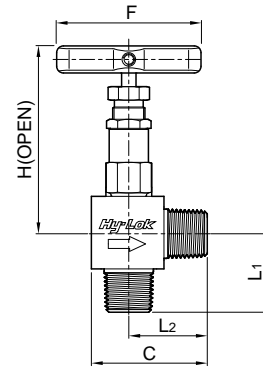

Angle pattern

Table of Dimensions

Basic Part No.	Orifice Hole	Cv	End Connections		Dimensions												
			Inlet	Outlet	L	L1	L2	C	S	F	H						
SVH2	F - 4N	5.0 (0.197)	0.52	1/4" Female NPT		52.4 (2.06)	26.2 (1.03)	26.2 (1.03)	54.1 (2.13)	32.0 (1.26)	64.0 (2.52)	88.5 (3.48)					
	F - 6N			3/8" Female NPT		66.7 (2.63)	33.3 (1.31)	33.3 (1.31)	57.2 (2.25)	38.1 (1.50)		91.5 (3.60)					
	F - 8N			1/2" Female NPT								77.8 (3.06)	44.5 (1.75)	33.3 (1.31)	57.2 (2.25)	38.1 (1.50)	91.5 (3.60)
	F - 12N			3/4" Female NPT		91.2 (3.59)	45.6 (1.80)	45.6 (1.80)	61.6 (2.43)	32.0 (1.26)							88.5 (3.48)
	MF - 8N			1/2" Male NPT	1/2" Female NPT												48.8 (1.92)
	MF - 12N			3/4" Male NPT	3/4" Female NPT	57.2 (2.25)	38.1 (1.50)										
	H - 6T			3/8" Hy-Lok		96.2 (3.79)	48.1 (1.89)	48.1 (1.89)	64.1 (2.52)				88.5 (3.48)				
	H - 8T			1/2" Hy-Lok													

Dimensions in millimeters(inches) are for reference only, subject to change.

Technical Data

SVH1,2

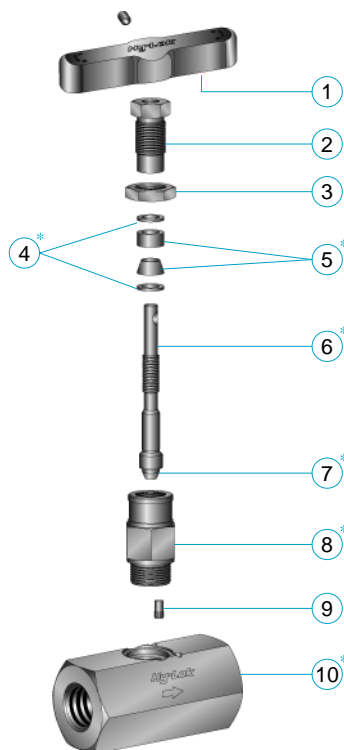

Materials of Construction

Description		Grade / ASTM Specification		
		Valve Body Materials		
		SS 316	Carbon Steel	Alloy 400
1	Handle	Stainless Steel	Aluminum Bar	Stainless Steel
2	Packing Bolt	SS316 / A479 or A276		
3	Lock Nut	SS316 / A276		
4	Packing Washer *	Reinforced PTFE		
5	Stem Packing *	PTFE		
6	Stem *	SS316 / A479 or A276		Alloy 400 / B164
7	Stem Tip *	Vee	SS630 / A564	
		Ball		
8	Bonnet *	SS 316 / A479	1020 / A108 or JIS 4051 S20C	Alloy 400 / B164
9	Stop Pin	Stainless Steel		
10	Body *	SS 316 / A479	1020 / A108 or JIS 4051 S20C	Alloy 400 / B164

Note : "*"marked are wetted parts.

Temperature and Pressure Rating

Series	Packing Material	Body Material	Temperature Range	Pressure Rating @ 100°F	Pressure Rating @ Max. Temperature
SVH1	PTFE	Stainless Steel	-65°F ~ 450°F (-54°C ~ 232°C)	10,000 psig	7,435 psig @ 450°F (512 bar @ 232°C)
		Carbon Steel	-20°F ~ 350°F (-29°C ~ 176°C)	10,000 psig	7,435 psig @ 450°F (512 bar @ 232°C)
SVH2	PTFE	Stainless Steel	-65°F ~ 450°F (-54°C ~ 232°C)	6,000 psig	4,130 psig @ 450°F (285 bar @ 232°C)
		Carbon Steel	-20°F ~ 350°F (-29°C ~ 176°C)	6,000 psig	5,230 psig @ 350°F (360 bar @ 176°C)
		Alloy 400	-65°F ~ 450°F (-54°C ~ 232°C)	5,000 psig	3,970 psig @ 450°F (274 bar @ 232°C)
	Graphite	Stainless Steel	-65°F ~ 1000°F (-54°C ~ 537°C)	6,000 psig	1,715 psig @ 1000°F (118 bar @ 537°C)
		Carbon Steel	-20°F ~ 350°F (-29°C ~ 176°C)	6,000 psig	5,230 psig @ 350°F (360 bar @ 176°C)
		Alloy 400	-65°F ~ 500°F (-54°C ~ 260°C)	5,000 psig	3,960 psig @ 500°F ^(a) (273 bar @ 260°C)

(a) Not applicable over 500°F(260°C)

Testing

Each high pressure bar stock needle valve is tested with nitrogen @ 1000 psig (69 bar) to Max. leak rate of 0.1 SCCM. Hydrostatic shell test is performed at 1.5 times the working pressure as an option. Other tests are upon request.

Sour Gas Service

Valves are available in materials which comply with standard NACE MR-01-75 latest revision relating to metallic materials offering optimum resistance to sulfide stress cracking

Maintenance Kits (See page 3)

Basic Ordering No.	Valve Type	Component	Stem Tip Shape	Designator
KIT-SVH1-SET- **	SVH1	Bonnet, Stem tip, Stem, Stem Packing, Packing Washer, Packing bolt, Handle, Lock nut, Set screw, Locking pin	Vee	V
			Ball	B
KIT-SVH2-SET- **	SVH2	Bonnet, Stem tip, Stem, Stem Packing, Packing Washer, Packing Gland, Packing bolt, Handle, Lock nut, Set screw, Locking pin	Packing Mat'l	Designator
			PTFE	T
			Graphite	G

* For a complete ordering number, add the desired stem tip shape & packing material designator as a suffix to the maintenance kit basic ordering number
 e.g : KIT-SVH1-SET-VT (Vee tip, PTFE stem packing)

Ordering Information

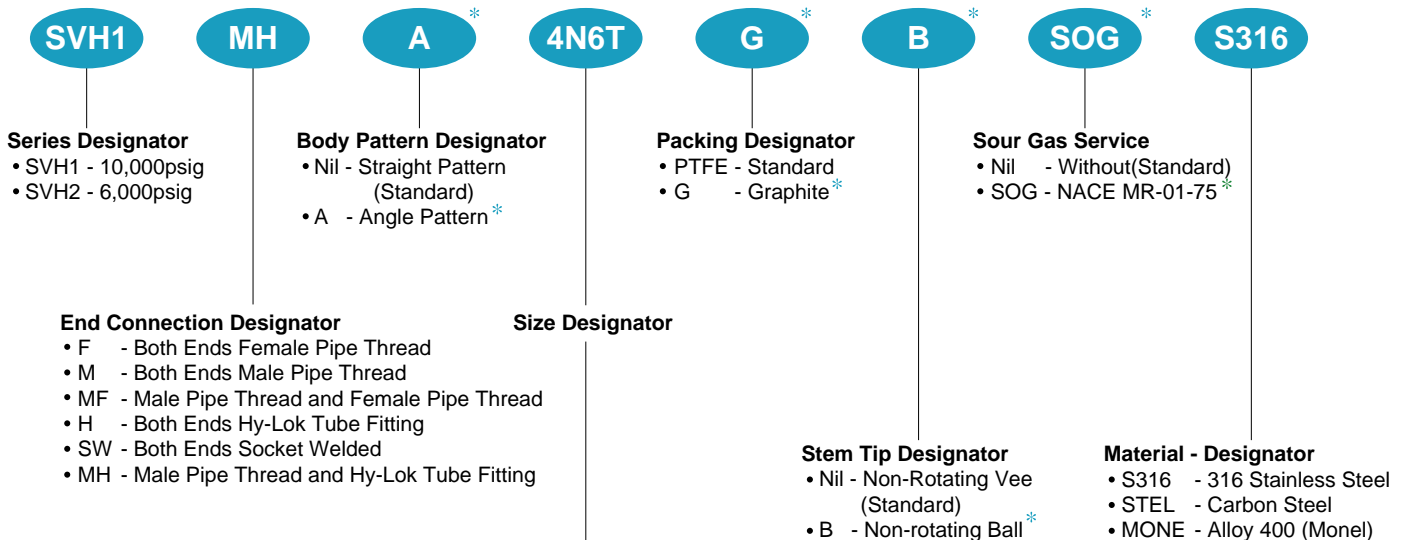

Pipe Thread Designation NPT (ISO / BSP)

Nom. Size	1 / 8	1 / 4	3 / 8	1 / 2	3 / 4	1
Designator	2N(R)	4N(R)	6N(R)	8N(R)	12N(R)	16N(R)

Tube O.D. Designation

Inch Tube	Tube O.D.	1 / 8	1 / 4	3 / 8	1 / 2	3 / 4	1
	Designation	2T	4T	6T	8T	12T	16T
Metric Tube	Tube O.D.	3mm	6mm	10mm	12mm	20mm	25mm
	Designation	3M	6M	10M	12M	20M	25M

Note * : No designator is required for standard
 e.g. SVH1F - 8N - S316

SAFETY in VALVE SELECTION

Proper installation, material compatibility, operation and maintenance of the valves is the responsibility of the user. The total system design must be taken into consideration to ensure optimal performance and safety.