



Bleed and Purge Valves

Bleed Valves

■ Features

- Pressure rating up to 10,000psig(689bar) at 100°F(37°C).
- Temperature rating from -65°F to 850°F (-54°C to 454°C) with stainless steel, from -20°F to 450°F(-29°C to 232°C) with carbon steel, from -65°F to 500°F (-54°C to 260°C) with alloy 400.
- Back stop screw prevents accidental remove of stem.
- Stem thread and tips are chrome-plated for maximum service life.
- Size range from 1/8" thru 1/2" tubing and piping system.
- Variety of end connections including Hy-Lok tube fittings, male/female NPT and ISO, SAE threads.



■ Materials of Construction

Description	Body Materials		
	Grade / ASTM Specification		
	SS316	Carbon Steel	Alloy 400
Body ^①	SS316 / A479	1020 / A108 or JIS 4051 S20C	Alloy 400 / B164
Stem	SS316 / A479 or A276		
Back Stop Screw			
Vent Tube	SS316 / A213		Alloy 400 / B164

^① Male Straight thread(SAE) body with FKM O-ring.(e.g Viton)

■ Applications

Hy-Lok bleed valves can be used on instrumental fluid handling apparatus such as manifolds or gauge/root valves in order to vent signal line pressure to atmosphere before disassemble of an instrument or to facilitate in calibration of control devices.

■ Testing

- Each valve is tested with nitrogen @1000psig(69bar) to max leak rate of 0.1 SCCM.
- Hydrostatic shell test is performed at 1.5 times the working pressure as an option.
- Other tests are available upon request

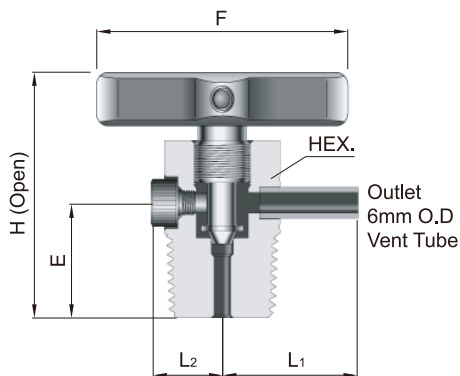

■ Table of Dimension

Basic Part Number	Orifice (Cv)	Inlet End Connection	Dimensions											
			E		F		H		L		L1		Hex.	
			in.	mm	in.	mm	in.	mm	in.	mm	in.	mm	in.	mm
BLV	-2N	1/8 Male NPT	0.75	19.1	2.0	50.8	1.61	41.0	0.94	23.9	0.56	14.3	5/8	15.8
	-4N	1/4 Male NPT	0.75	19.1			1.61	41.0	0.94	23.9	0.56	14.3	5/8	15.8
	-6N	3/8 Male NPT	0.87	22.1			1.73	44.0	1.03	26.1	0.59	15.1	7/8	22.2
	-8N	1/2 Male NPT	0.87	22.1			1.73	44.0	1.03	26.1	0.59	15.1	7/8	22.2
	-4U	SAE 7/16-20	0.77	19.6			1.63	41.5	1.03	26.1	0.59	15.1	7/8	22.2
	-8U	SAE 3/4-16	0.82	20.8			1.68	42.7	1.03	26.1	0.59	15.1	7/8	22.2

Dimensions are for reference only, subject to change.



Bleed and Purge Valves

Option

Hex Head Stem

To order, add designator - HS as a suffix to the basic part number.
Example : BLV - 8N - HS

Barbed Vent Tube

To order, add designator - B as a suffix to the basic part number.
Example : BLV - 8N - B

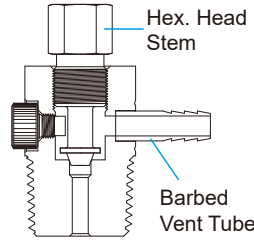

CAUTION

When installing a Hy-Lok bleed valves, the vent tube should be positioned not to influence the fluid system on operators.

Be sure that bleed valves should be always slowly opened in order to protect operators from exposure to hazardous system fluids.

How To Order

Use S316 for 316 stainless steel or STEL for carbon steel, MONE for alloy 400 as a suffix to the basic part number.
Example : BLV - 4N - S316

Features

- Pressure rating up to 4,000psig(275bar) for 316 stainless steel and up to 3,000psig(206bar) for Carbon Steel and Brass at 100°F(38°C).
- Temperature rating from -65°F to 600°F(-54°C to 315°C) with Stainless Steel, from -65°F to 400°F(-54°C to 204°C) with carbon steel, from -20°F to 350°F (-29°C to 177°C) with brass.
- Vent hole is bleeds excessive liquid or gas from system lines.
- Knurled cap is crimped to valve body for prevents accidental remove from body.
- Size range from 1/8" thru 1/2" tubing and piping system.
- Variety of end connections including Hy-Lok tube fittings, male/female NPT and ISO, SAE threads.



Materials of Construction

Description	Body Materials		
	Grade / ASTM Specification		
	SS316	Carbon Steel	Brass
Body ¹⁾			
Knured Cap	SS316 / A479	1020 / A108 or JIS 4051 S20C	JIS H3250 C3604BD
Poppet	SS316		
Spring	SS302		

¹⁾ Temperature rating is limited to -20°F (-28°C) min.

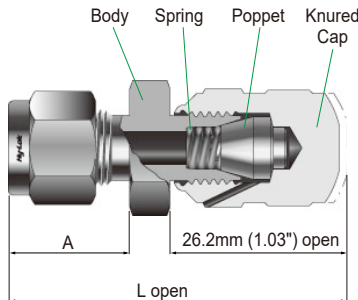

Option

PTFE Poppet

PTFE poppet provides leak tight shut - off with finger.
Pressure rating up to 200 psig (13.7bar) at 100°F (37°C)
Temperature rating up to 300°F (176°C)
To order, add designator - P as a suffix to the basic part number.
Example : PV H - 8T - P

CAUTION

When installing a Hy-Lok purge valves, the vent hole should be positioned not to influence the system fluid on operators. As the vent hole turns with the cap, discharging the valve is executed by turning the cap. Be sure that purge valves should be always slowly opened in order to protect operators from exposure to hazardous system fluids.

How To Order

Use S316 for 316 stainless steel or STEL for carbon steel, BRAS for brass as a suffix to the basic part number.
Example : PV H - 4T - S316

Applications

Hy-Lok Purge valves are for bleed, vent or drain purpose manually. The knurled cap is not separable from the valve body for safety purpose. 1/4 turns of wrench pull-up from finger tight give leak-free closure on first make-up. Proper tightening with a wrench secures closure to the desired pressure rate with sufficient make-ups.

Table of Dimension

Basic Part Number	Inlet End Connection	Dimensions			
		A		L	
		in.	mm	in.	mm
F -2N	1/8 Female NPT	0.53	13.5	1.56	39.6
F -4N	1/4 Female NPT	0.72	18.3	1.75	44.4
F -6N	3/8 Female NPT	0.78	19.8	1.81	46.0
F -8N	1/2 Female NPT	0.97	24.6	1.98	50.3
M -2N	1/8 Male NPT	0.38	9.7	1.62	41.1
M -4N	1/4 Male NPT	0.56	14.2	1.81	46.0
M -6N	3/8 Male NPT	0.56	14.2	1.84	46.7
M -8N	1/2 Male NPT	0.75	19.1	2.09	53.1
M -4U	7/16-20 Male Unified	0.38	9.7	1.69	42.9
M -8U	3/4-16 Male Unified	0.44	11.2	1.81	46.0
H -2T	1/8 Hy-Lok	0.59	15.24	1.84	46.7
H -4T	1/4 Hy-Lok	0.69	17.78	1.94	49.3
H -6T	3/8 Hy-Lok	0.75	19.3	2.03	51.6
H -8T	1/2 Hy-Lok	0.88	21.84	2.19	55.6
H -6M	6mm Hy-Lok	0.69	17.7	1.94	49.3
H -8M	8mm Hy-Lok	0.72	18.6	2.0	50.8
T -4T	1/4 Tube Stub	0.63	16.0	1.87	47.5
T -6T	3/8 Tube Stub	0.69	17.5	1.94	49.3
T -8T	1/2 Tube Stub	0.91	23.1	2.15	54.6

Dimensions are for reference only, subject to change.